

Industrial Inkjet

RICOH TH6310F

RICOH
imagine. change.

Achieving high image quality printing with wide print gap using MEMS technology that enables precise jetting and nozzle placement optimization. The ink circulation mechanism meets both multi and single pass application needs with high reliability.

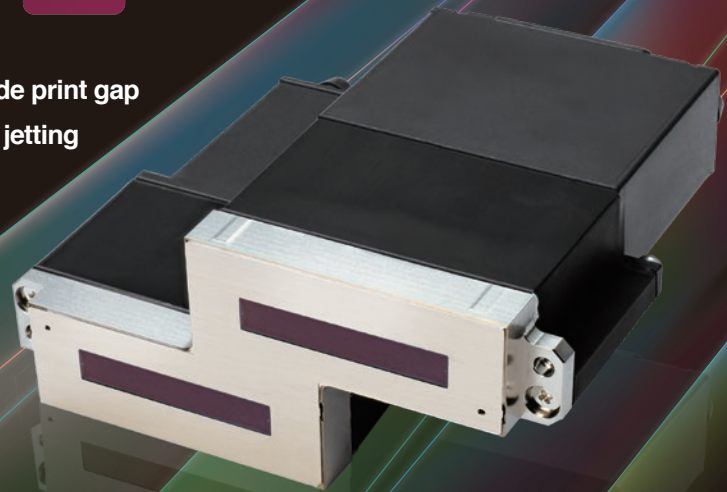

Precise control of an ink droplet landing position even with wide print gap

In addition to high precision jetting enabled by MEMS technology, that achieves a nozzle placement design that avoids air flow influencing adjacent drops and effecting the image quality, and also achieves a stable ink droplet landing on media with a wide print gap and results in high image quality printing.



Simple Design

One in/out ink tube connection enables a simple ink delivery system for designing a printer.

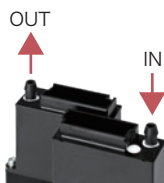

Improved printing reliability with the ink circulation mechanism

Reduces the risk of missing jets due to nozzle dryness and ink particle sedimentation by circulating ink behind the nozzles.

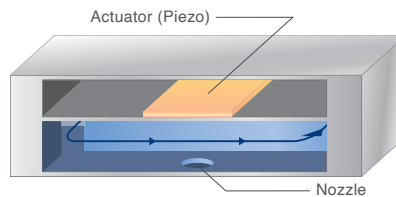

High productivity at 600dpi multi-drop jetting

It enables ink jetting at 80kHz at 5pl binary driving or 40kHz at 5/10/18pl multi-drop driving. It also achieves the high productivity of 100m+/minute print speed at 600 dpi.

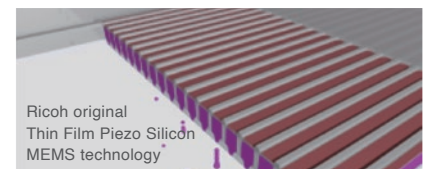

Ink Compatibility

It is compatible with all types of ink such as Aqueous, UV and Solvent for wide applications from Textile/Label to Corrugated.

Aqueous UV Solvent



High resolution and high productivity thin-film piezo inkjet printhead for wide applications from Textile to Label

RICOH TH6310F

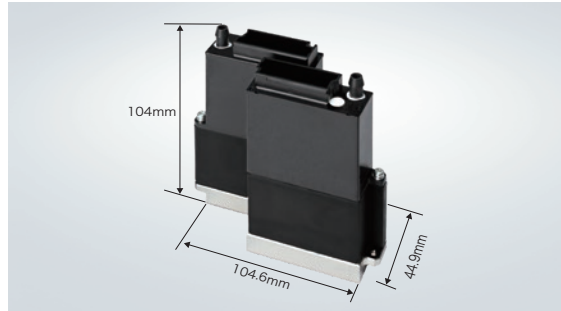

RICOH TH6310F	
Method	Thin-film piezoelectric transducer with bend mode
Print Width	66.7mm
Number of nozzles	1,600 (8 × 100 channels × 2 Modules), staggered (Net: 1,576)
Nozzle Resolution	600dpi
Nozzle spacing (Row to row distance)	A: 0.677mm (8 pixels of 600dpi) B: 20.909mm (494 pixels of 600dpi)
Compatible ink	Aqueous, UV, Solvent, Others.
Total printhead dimensions	W : 104.6mm D : 44.9mm H : 104mm
Weight	374g
Max.number of color inks	1 color
Operating temperature range	60°C
Temperature control	Integrated thermistor, heater
Firing frequency	80kHz (2 levels) 60kHz (3 levels) 40kHz (4 levels)
Greyscale	4 levels
Drop volume	5pL (Single drop) 5 ~ 18pL (Multi drop)
Viscosity range	5.5mPa · s
Surface tension	31.6±5mN/m
Ink circulation structure	Supported
Separately sold parts	TH6310F dedicated cable

■ Nozzle

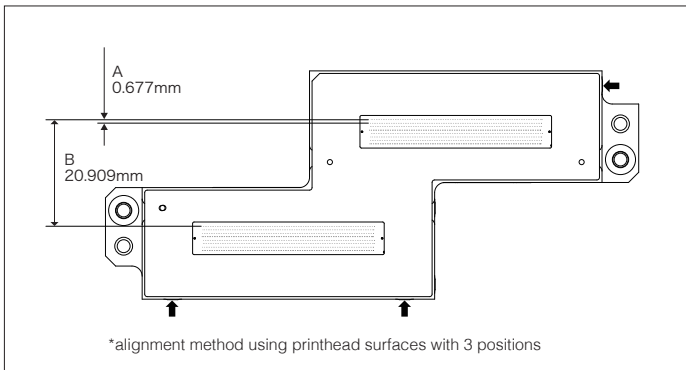

■ External dimensions

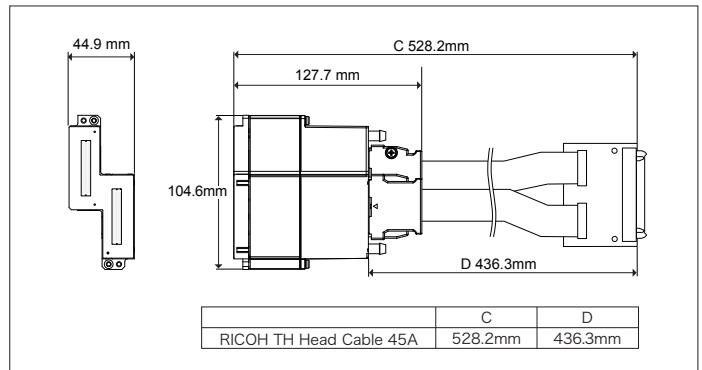

- Product appearance and specifications may be changed without prior notice for improvement purpose.
- Please contact your sales representative for details on performance, specifications, and restricting conditions, etc
- Company and product names are trademarks or registered trademarks of their respective companies

RICOH
imagine. change.

● Inquiries and orders: