

Industrial Inkjet

RICOH GH2220

RICOH
imagine. change.

Silicon based Printhead Technology
Delivering excellent cost performance
for sign graphics, textile and coding
and marking Markets.

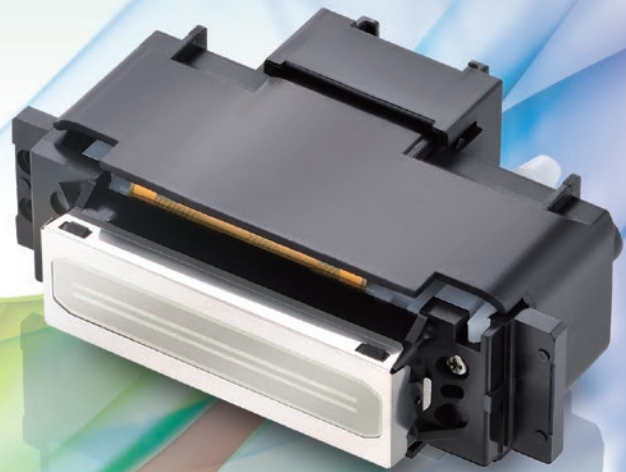

**Expanding industrial opportunities
with new precision fabricated silicon range.**

Introducing the new GH Printhead to complement Ricoh's stainless steel MH series Printhead family. The GH Printhead is a result of over 10 years of Ricoh research and manufacturing optimization and is now made available for OEMs to incorporate in their aqueous and solvent ink based printer offerings.



* Image of printed results

**Supports
water and solvent based inks.**

In addition to water-based inks, these printheads support solvent inks as well.

**Multi-drop technology enables
grey scale expressions**

These Printheads support multi-drop-based droplet control for instantly consolidating the ink that is discharged from the nozzle at high speeds before it reaches the surface of the medium. Droplet volume control enables full control of ink discharge from small to large droplets.

Expanding industrial opportunities with new precision fabricated silicon range.

GH2220

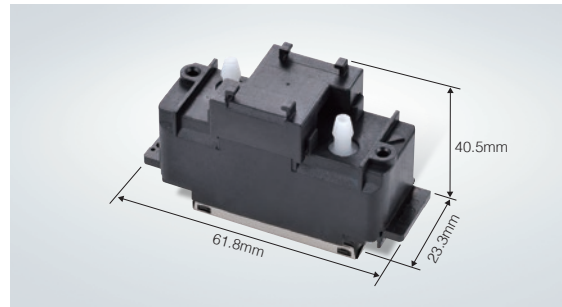

GH2220	
Method	Piston pusher with metallic diaphragm plate
Print Width	32.4 mm(1.28")
Number of nozzles	384
Nozzle spacing (Within a row)	1/150"(0.1693 mm)/row
Nozzle spacing (Row to row distance)	0.931 mm
Compatible ink	Aqueous, Solvent
Total printhead dimensions	61.8(W) × 23.3(D) × 40.5(H) mm (2.43" × 0.92" × 1.59")
Weight	38 g
Max.number of color inks	2 colors
Temperature control	No heater or thermistor
Life	30 billion actuations per nozzle
Jetting frequency	Binary mode : 30kHz / Grey-scale : 24kHz
Drop volume	Binary mode : 3-5pl / Grey-scale : 21±2pl *depending on the ink
Viscosity range	8±0.5mPa·s(@25°C)
Surface tension	25±5mN/m (@23±2°C)
Maximum grey scale	4 levels * depends on ink characteristics
Alignment mechanism	Frame-abutting

* Results obtained from continuous jetting test using standard Ricoh test ink.

■ Nozzle

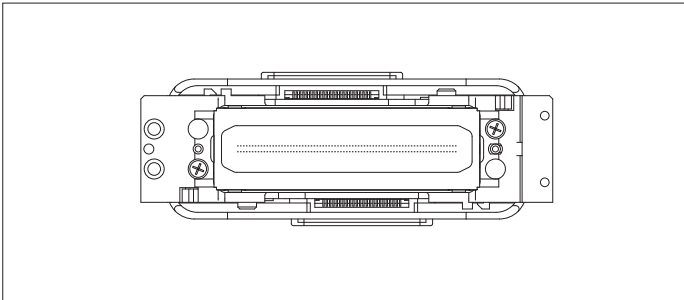

■ External dimensions

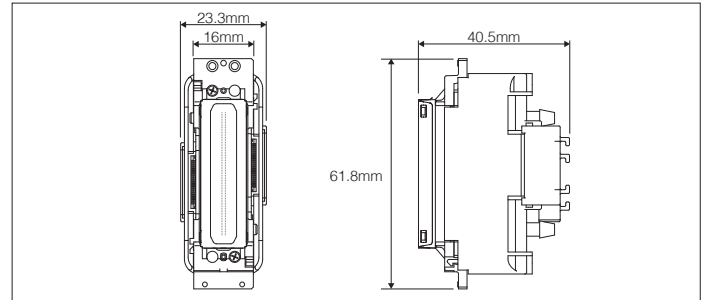

- Product appearance and specifications may be changed without prior notice for improvement purpose.
- Company and product names are trademarks or registered trademarks of their respective companies
- Please contact your sales representative for details on performance, specifications, and restricting conditions, etc

RICOH
imagine. change.

● Inquiries and orders: